

SDKELI[®]

KLM LIDAR - Obstacle Avoidance Type

OPERATION MANUAL

(January 2026)



Jining Keli Photoelectric Industrial Co., Ltd.

Directives and standards

KLM series laser scanner (referred to as KLM) meets the following standards:

- European Union Directive
EMC Directive 2014/30/EU
- International standard
IEC 61496-1 (Type 3) IEC 61496-3 (Type 3)
IEC 61508-1: 2010 (SIL 2) EN 13849-1 (PL d)
EN 60825-1: 2014 (Class 1 laser product)
EN 61326-1: 2013
EN 61000-4-2: 2009
EN 61000-4-3: 2006 + A1: 2008 + A2: 2010
EN 61000-4-4: 2004 + A1: 2010
EN 61000-4-6: 2009
EN 61000-4-8: 2010 EN 61000-4-11: 2004
- GB standard
GB 4208-2017 (IP65/IP67)

Safety precautions



This is a key information prompt symbol.
The contents indicated under this symbol are very important.
Operators must understand and strictly comply with the requirements to avoid potential unexpected safety incidents.

Safety precautions for use



- Before using KLM, carefully read this manual to understand the procedures and requirements for installation, operation, and configuration.
- KLM should be selected, installed, maintained, and serviced by qualified personnel. Qualified personnel refer to those who have received professional training and hold recognized qualifications, or individuals with extensive knowledge, training, and experience who have demonstrated the ability to handle such tasks.
- KLM is a Class 1 laser product (eye-safe); the laser beam is invisible to the human eye. Using controls, adjustments, or procedures not specified in this manual may result in hazardous radiation exposure.
- When configuring the lidar via the USB port, first ensure that the lidar housing is not electrically charged. Confirm that the lidar housing is in a non-electrified condition before making any connections. Use a multimeter to measure the voltage between the non-painted surface of the lidar housing (e.g., the mounting thread holes) and the 0V power supply terminal of the lidar. Ensure that this value is $\leq 10V$.
- KLM should be used at locations with an altitude of $\leq 2000m$ above sea level.
- Do not drop KLM.
- The use of KLM must comply with local standards, laws, and regulations.
- The user should establish and effectively implement safety operation management rules and regulations.

Applications

KLM is suitable for collision prevention of mobile robots. The typical application is automated guided vehicle (AGV) and rail guided vehicle (RGV).

- The detection object of KLM must meet the following conditions:
 - Only protect the objects that go into the detection zone.
 - KLM cannot detect transparent and translucent objects.
 - The size of objects that go into the detection zone must be greater than or equal to the detection capability of KLM.
- Do not install KLM in the following environments:
 - Places outside the range of environment specified in the Operation Instructions (temperature, humidity, interference light, impact and vibration).
 - Places with flammable or explosive gas.
 - Places with smoke, particles, corrosive chemicals and other substances.
 - Places that may generate strong light interference (such as direct light) on the KLM.

1. Working principles

KLM is designed based on pulsed laser ranging principles to realize the two dimensional zone detection with an angle of 276° and radius of 30m @10% reflectance through rotational scanning.

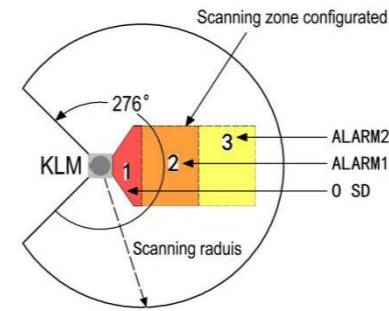

Identification	Meaning	Description
1	Protection zone	OSSD will enter OFF state when any obstacle is detected in protection zone
2	Alarm zone 1	ALARM1 will enter OFF state when any obstacle is detected in alarm zone 1
3	Alarm zone 2	ALARM2 will enter OFF state when any obstacle is detected in alarm zone 2

2. Appearance information

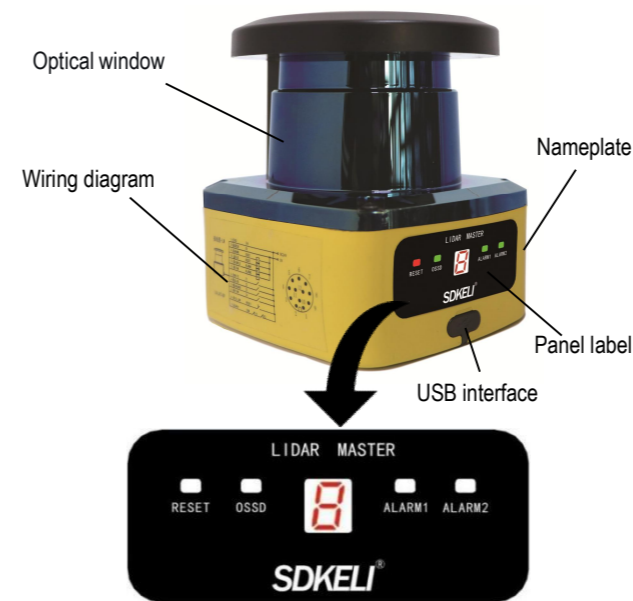

Be sure to press the black sealing cover on the USB interface tightly to prevent moisture, dust, etc. from entering the KLM, so as not to affect the use and life of the lidar.

Identification	Indicator	Description
RESET	Reset	Under manual reset mode, red lights when any obstacle is detected in protection zone
OSSD	Output of protection	Red is on when any obstacle is detected in protection zone to make OSSD enter OFF state, and green is on when there is no obstacle
ALARM1	Output of alarm zone 1	Red is on when any obstacle is detected in alarm zone 1 to make ALARM1 enter OFF state, and green is on when there is no obstacle
ALARM2	Output of alarm zone 2	Red is on when any obstacle is detected in alarm zone 2 to make ALARM2 enter OFF state, and green is on when there is no obstacle
	0	Detection zone is not configured or there is input signal failure
	1	The current scanning zone is zone group 1
	2	The current scanning zone is zone group 2
	3	The current scanning zone is zone group 3
	4	The current scanning zone is zone group 4
	7	The current scanning zone is zone group 5
	0	The current scanning zone is zone group 6
	5	The current scanning zone is zone group 7
	11	The current scanning zone is zone group 8
	7	The current scanning zone is zone group 9
	0	The current scanning zone is zone group 10
	9	The current scanning zone is zone group 11
	11	The current scanning zone is zone group 12
	7	The current scanning zone is zone group 13
	9	The current scanning zone is zone group 14
	2	The current scanning zone is zone group 15
	11	The current scanning zone is zone group 16
	5	Fault of OSSD output
	6	Establish a communication connection with computer
	8	Flashing during power-on initialization
	9	KLM configuration is finished
	E	Fault of EDM monitor
	F	KLM system fails
	C	Window dirty display, activated when the window is dirty
		When multiple statuses coexist, multiple status words are displayed cyclically (with an interval of 1 second)

3. Specification

Series Scan radius Scan range Output form Installation code
 KLM — □□ □□ □□ / □□

Specification	Scan radius	Scan range	Output form
KLM-0827BP	8m@1.8% reflectance 20m@10% reflectance	276°	PNP
KLM-1227BP	12m@1.8% reflectance 30m@10% reflectance	276°	PNP

Installation code: SZ: Horizontal installation/CZ: Vertical installation

4. Power/output interface

The power/output interface is a M12-12 core hole head, the cable length is 0.3m.

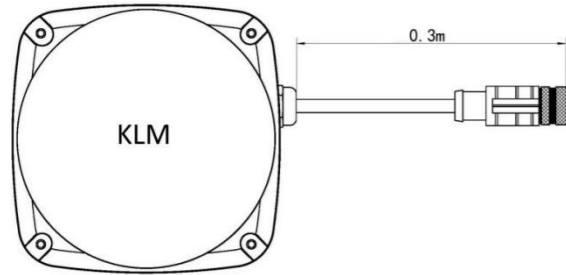

Output interface	Color	Signal definition	Signal description
	1-Red	24V	Working power supply
	2-Green	0V	
	3-White	Z1	Zone group selection signal. Switching among multiple protection zones can be achieved through the changes in Z1, Z2, Z3 and Z4 input signals
	4-Black	Z2	
	5-Orange	Z3	
	6-Pink	Z4	
7-Gray	EDM	External contact monitor input signal. When OSSD is ON, EDM=0V; when OSSD is OFF, EDM=24V	
8-Yellow	RESET	When manual rest, input reset signal to release output lock to start again	
9-Brown	OSSD1	2 independent PNP output It is in the ON state when no object is present in the protection zone, and switches to the OFF state when an object is detected or a fault occurs.	
10-Blue	OSSD2		
11-Purple	ALARM1	2 independent PNP output It is in the ON state when no object is present in the alarm zone, and switches to the OFF state when an object is detected.	
12-Cyan	ALARM2		

5. Transmission cable

The transmission cable is a 12-core shielded cable with an M12-12 core needle at one end, which is connected to the power/output interface, and the other end of each core is stripped and tinned to connect to the device. For the color and function definition of each core, see the power/output interface. The standard wiring length of the transmission cable is 3m.

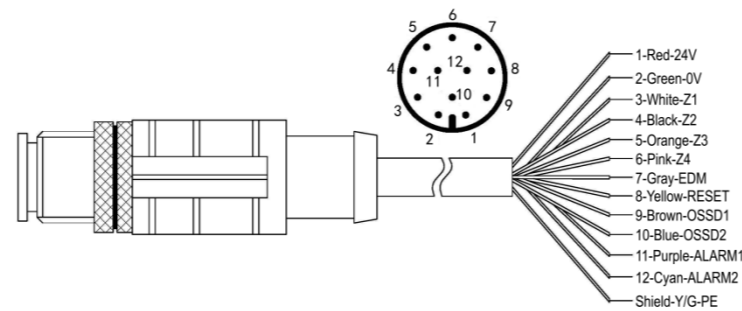

6. Technical parameters

Laser light source	Wavelength: 905nm; Class 1 laser product	
Max. detection range	30m@10% reflectance	
Scanning angle range	276°	
Angular resolution	0.12°	
Measurement accuracy	≤25mm (Typical value)	
Repeat accuracy	±6mm@1sigma ¹	
Working voltage	DC11V to DC28V	
Power-on time	10s (Typical value)	
Refresh frequency	25Hz	
Power consumption	8W (Typical value)	
Output form	PNP	
Safety output (OSSD)	PNP×2 (ON state: Max. I _{OUT} =200mA, V _{OUT} ≥V _{CC} -2V, OFF state: I _{OUT} <1mA, V _{OUT} <2V). Overcurrent protection, capacitive load ≤60nF. It is in the ON state when no object is present in the protection zone, and switches to the OFF state when an object is detected or a fault occurs.	
Alarm output (ALARM)	PNP×2 (ON state: Max. I _{OUT} =200mA, V _{OUT} ≥V _{CC} -2V, OFF state: I _{OUT} <1mA, V _{OUT} <2V). Overcurrent protection. It is in the ON state when no object is present in the alarm zone, and switches to the OFF state when an object is detected.	
Dimensions	100mm×100mm×115mm	
Ambient temperature	Operating	-30°C to 50°C (non-condensing)
	Storage	-40°C to 70°C
Ambient humidity	Operating	35%RH to 85%RH
	Storage	35%RH to 95%RH
Anti-light interference	80000Lux	
Shock resistance	Acceleration: 10g; Pulse duration: 16ms; Number of collision times: three axes, 1000 ± 10 times per axis	
Vibration resistance	Frequency 10Hz to 55Hz; Amplitude: 0.35 ± 0.05mm; Number of scans: three axes, 20 times per axis	
IP code	IP65/IP67	
EMC	EN 61326-1: 2013	
	EN 61000-4-2: 2009	
	EN 61000-4-3: 2006 + A1: 2008 + A2: 2010	
	EN 61000-4-4: 2004 + A1: 2010	
	EN 61000-4-6: 2009	
	EN 61000-4-8: 2010	
	EN 61000-4-11: 2004	

1) This value is obtained by testing the target plate with 10% reflectance at a distance of 1m from KLM.

7. Overall dimensions

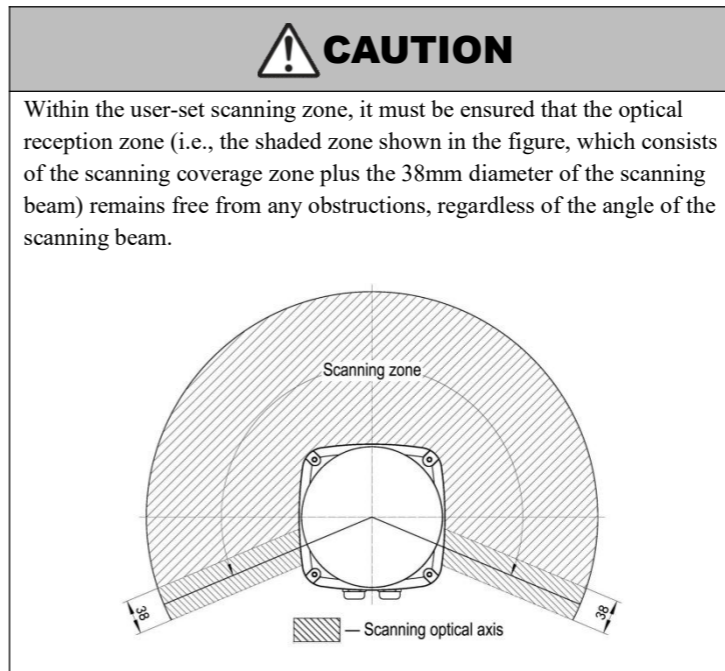
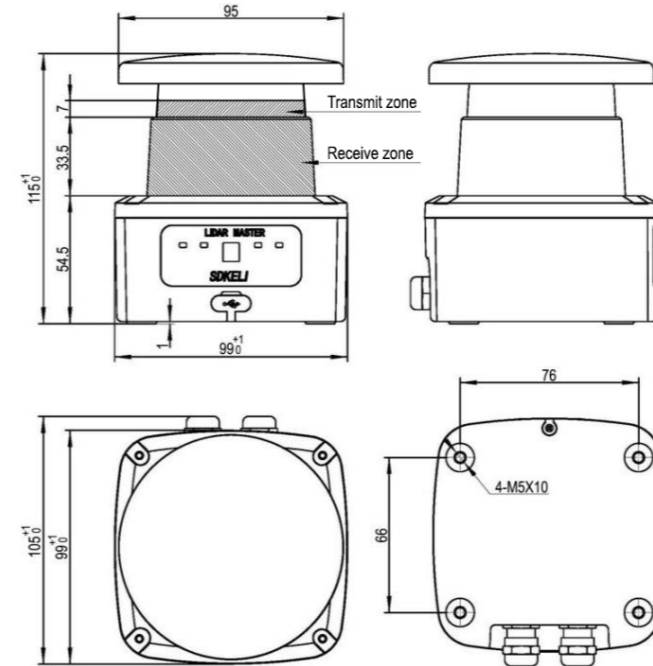

8. Installation

Horizontal installation (SZ)

- Horizontal mounting bracket
- Anti-shock bracket
- M5×6 countersunk head screws × 12pcs
- Rubber shock absorber × 4pcs

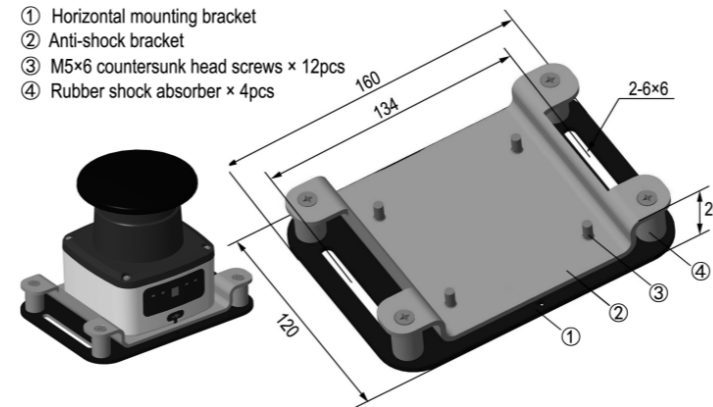

Vertical installation (CZ)

- Vertical mounting bracket
- Anti-shock bracket
- M5×6 countersunk head screws × 12pcs
- Rubber shock absorber × 4pcs

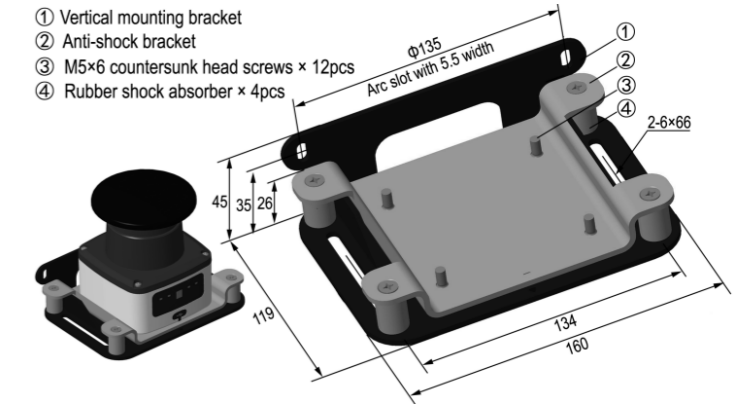

CAUTION

- To prevent the optical path from projecting onto the ground, the mounting height of the KLM (i.e., the height from the centerline of the emission zone to the ground) shall exceed 0.026 times the radius of the detection area.
- During installation, ensure the parallelism between the installation plane and the scanning plane to prevent false triggering caused by the inability of detecting obstacles or detecting obstacles other than the target due to the inclination of the scanning plane.
- Try to keep KLM away from the vibration area during installation.

9. Wiring

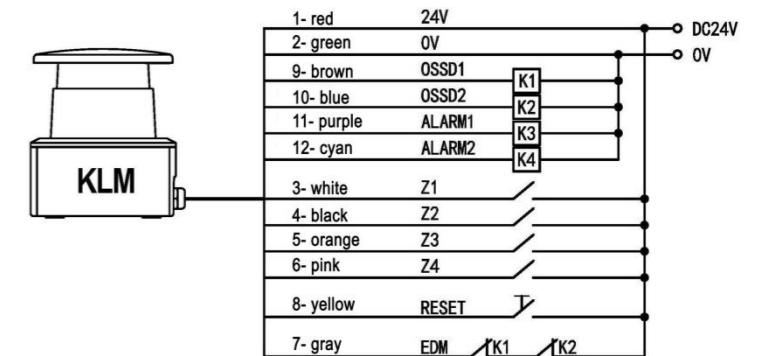

CAUTION

- Please read this manual carefully before wiring.
- Wiring must be conducted when the power is cut off.
- Double insulation or reinforced insulation must be used between all input and output interfaces and dangerous voltage. Otherwise, electric shock may be caused.
- The cable must be kept away from high-voltage wires and power lines.
- It is strictly forbidden for users to replace the cable without permission.
- Conduct correct wiring after defining the signal meanings of all terminals.